

(Hotplate) Magnetic Stirrer

User Manual

LCD Digital Hotplate Magnetic Stirrer

Classic Hotplate Magnetic Stirrer

LCD Digital Magnetic Stirrer

Classic Magnetic Stirrer



Please read the User Manual carefully before use, and follow all operating and safety instructions!

Technical specifications and outline are subject to change without prior notice.

Contents

Preface.....	1
Service.....	1
Warranty	1
1. Safety Instructions.....	2
2. Proper Use	3
3. Inspection	4
3.1 Receiving Inspection	4
3.2 Listing of Items	4
4. Control.....	5
4.1 Control elements.....	5
4.2 Display (LCD digital model).....	7
5. Trial Run.....	7
6. Function: Heating (LCD digital hotplate model).....	8
6.1 Working with external temperature sensor	9
6.2 Residual heat warning (HOT)	9
7. Stirring (LCD digital model).....	9
8. Remote Control (LCD digital model).....	10
9. Faults	10
10. Maintenance and Cleaning	11
11. Associated Standards and Regulations.....	12
12. Specifications	13

Preface

Welcome to the “(Hotplate) Magnetic Stirrer User Manual”. Users should read this Manual carefully, follow the instructions and procedures, and be aware of all the cautions when using this instrument.

Service

When help needed, you can always contact the Service Department of manufacturer for technical support in the following ways:

Please provide the customer care representative with the following information:

- Serial number (on the rear panel)
- Certification
- Description of problem (i.e., hardware or software)
- Methods and procedures adopted to resolve the problems
- Your contact information

Warranty

This instrument is warranted to be free from defects in materials and workmanship under normal use and service, for a period of 24 months from the date of invoice. The warranty is extended only to the original purchaser. It shall not apply to any product or parts which have been damaged on account of improper installation, improper connections, misuse, accident or abnormal conditions of operation.

For claims under the warranty please contact your local supplier. You may also send the instrument directly to manufacturer, enclosing the invoice copy and by giving reasons for the claim.

1. Safety Instructions



Warning!

- Read the operating instructions carefully before use.
- Ensure that only trained staff works with the instrument.



Risk of burn!

- Caution when touch the housing parts and the hotplate which can reach temperature of 340°C.
- Pay attention to the residual heat after switching off.



Protective ground contact!

- Make sure that socket must be grounded (protective ground contact) before use.

• When working wear personal safety guards to avoid the risk from:

- Splashing and evaporation of liquids
- Release of toxic or combustible gases

• Set up the instrument in a spacious area on a stable, clean, non-slip, dry and fireproof surface. Do not operate the instrument in explosive atmospheres, with hazardous

substances or under water.

- Gradually increase the speed, reduce the speed if:
 - Stirring bar breaks away due to high speed
 - The instrument is not running smoothly, or container moves on the base plate
- Temperature must always be set to at least 50°C lower than the fire point of the media used.
- Be aware of hazards due to:
 - Flammable materials or media with a low boiling temperature
 - Overfilling of media
 - Unsafe container
- Process pathogenic materials only in closed vessels.
- If the case of the stirrer bar is PTFE, please note:
 - Elemental fluorine, three fluoride and alkali metals will corrode the PTFE and Halogen alkanes make it expansion at room temperature
 - Molten alkali, alkaline earth metals or their solution, as well as the powder in second and third ethnic of the Periodic Table of Elements will have chemical reaction with PTFE when temperature reaches 300 ~ 400 °C .
- Check the instrument and accessories prior to each use. Do not use damaged components. Safe operation is only

guaranteed with the accessories described in the “Accessories” chapter. Accessories must be securely attached to the device and can not come off by themselves. Always disconnect the plug before fitting accessories.

- When the external temperature sensor needed, the tip of the measuring sensor must be at least 5-10mm from vessel bottom and wall.
- The instrument can only be disconnected from the main power supply by pulling out the main or the connector plug.
- The voltage stated on the label must correspond to the main power supply.
- Ensure that the main power supply cable does not touch the hotplate. Do not cover the device.
- The instrument may only be opened by experts.
- Keep away from high magnetic field.

2. Proper Use

The instrument is designed for mixing and/or heating liquids in schools, laboratories or factories.

- Observe the minimum distances between the devices, between the device and the wall and above the assembly (min. 100 mm)

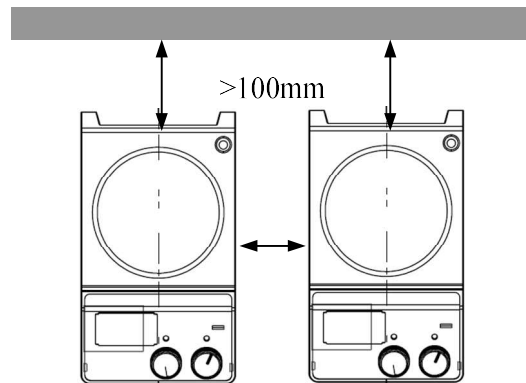

Figure 1

This device is not suitable for using in residential areas or other constraints mentioned in Chapter 1.

3. Inspection

3.1 Receiving Inspection

Unpack the equipment carefully and check for any damages which may have arisen during transport. Please contact manufacturer/supplier for technical support.

**Note:**

If there is any apparent damage to the system, please do not plug it into the power line.

3.2 Listing of Items

The package includes the following items:

Items	Qty
Main unit	1
Power cable	1
Stirrer bar	1
User Manual	1

Table 1

4. Control

4.1 Control elements

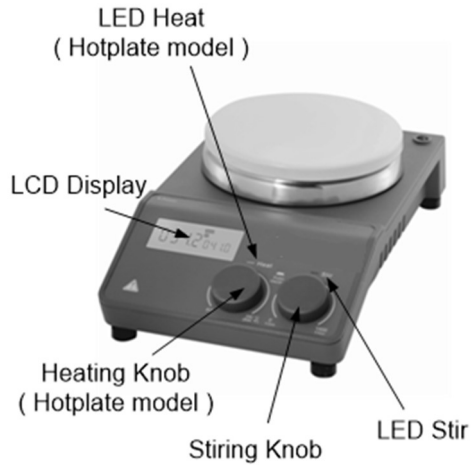

Figure 2 LCD Digital model

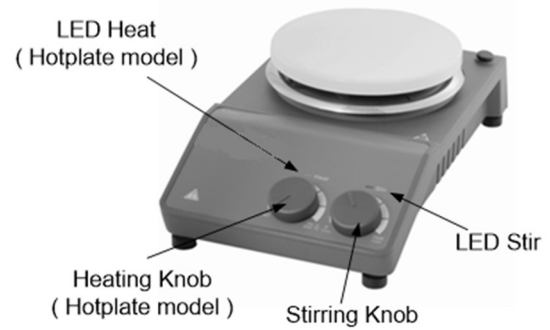

Figure 3 Classic model

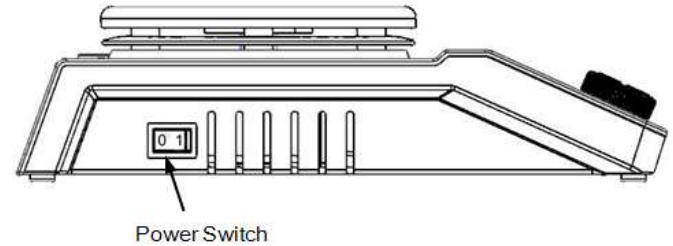

Figure 4

	Items	Descriptions
LCD Digital model	Stirring knob Stir	Set the rated rotary speed. The function “Stirring” is switched ON or OFF via push ON/OFF the knob.
	Heating knob Heat (Hotplate model)	Set the rated temperature. The function “heating” is switched ON or OFF via push ON/OFF the knob.
	LCD Display	LCD displays the real working state and all settings.
	LED Heat (Hotplate model)	When the heating function is switched ON, the LED Heat is lit.
	LED Stir	When the stirring function is switched ON, the LED Stir is lit.
	Power Switch	Switch ON or OFF the instrument.
Classic model	Stirring knob Stir	Set the rated rotary speed in the safe stirring range from 0 to 1500 rpm. The function “Stirring” is switched ON or OFF via the knob.
	Heating knob Heat (Hotplate model)	Set the rated temperature in the safe temperature range from room temperature to 340°C. The function “heating” is switched ON or OFF via the knob.
	LED heat (Hotplate model)	When the heating function is switched ON, the LED Heat is lit.
	LED Power	When the device is switched ON, the LED power is lit.
	Power switch	Switch ON or OFF.

Table 2

4.2 Display (LCD digital model)

Err	Display in case of error happening.
Rated value/Real value	Display value in case of heating or stirring function switching ON.

Table 3



Note:

If both heating and stirring functions have been started at the same time, heating function always has higher priority. If in this case speed is changed via the stirring knob, it displays stirring speed and reverses to temperature in the duration of 5 seconds.

Figure 5

Characters	Descriptions
Temp and °C	Display temperature when the heating function is switched ON.
Stir	Display stirring state when the stirring function is switched ON.
Hot	Display hot warning if the heating plate temperature is above 50°C after switching OFF the heating function.
Probe	Display when using external probe.
Remote	Display in case of remote control.

5. Trial Run

- Make sure the required operating voltage and power supply voltage match.
- Ensure the socket must be properly grounded.
- Plug in the power cable, ensure the power is on and begin initializing.
- Add the medium into the vessel with an appropriate stirring bar.
- Place vessel on the work plate.

- Set the target stirring speed and begin.
- Observe the stirring bar and LCD display (digital model).
- Set the target temperature and start heating.
- Observe the real temperature on LCD display (digital model).
- Stop the heating and stirring functions.

If these operations above are normal, the device is ready to operate. If these operations are not normal, the device may be damaged during transportation, please contact manufacturer/supplier for technical support.



Warning !

Forbid to transfer the vessel when the instrument working.

6. Function: Heating (LCD digital hotplate model)

The device is controlled by digital temperature control technology, which has two separate safe circuits. The hotplate is kept at a constant temperature by a digital control circuit. The hotplate temperature can also be monitored from a separate, adjustable safe circuit. The two temperature sensors (PT1000) internal for temperature

control are built into the hotplate. The single external PT1000 can monitor the temperature of sample.

- Plug in the external PT1000.
- Set the temperature via rotating the temperature control knob slowly to the target value.
- When the heating function is switched on, the LED “Heat” will light up and the LCD will display the real temperature.
- The rated temperature will be displayed on the right-hand side of the LCD as well as **Temp** and **°C** characters.
- The heating function is switched on or off by pushing heating knob.

Instrument is turned on for the setting zone temperature setting when the last shutdown temperature, the common case, set the heating temperature display the actual temperature may have the following differences:

- Hotplate center and outer edge.
- The sample container and the container.

In order to ensure the accuracy of the temperature inside the container, please use the external temperature sensor PT1000.

6.1 Working with external temperature sensor

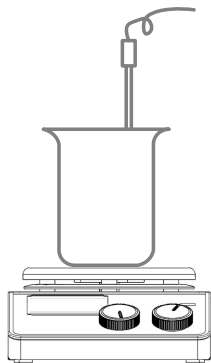

Figure 6

The external temperature sensor PT1000 is the manufacture's standard accessory. If the sensor is plugged in, "Probe" will be shown on the digital display to indicate the sensor is operating. The setting value of external temperature sensors and actual temperature are displayed. Safe circuit controls hotplate temperature.

Comparing with the temperature control of the hotplate, the external temperature sensor can control the medium's temperature more precisely.

6.2 Residual heat warning (HOT)

In order to prevent the risk of burns from a hotplate, digital hotplate has a residual heat warning function. When the heating function is switched off and the heating plate temperature is still above 50°C, "Hot" will flash to warn that there is a hazard of burns from the hotplate. When the hotplate temperature drops to below 50°C, the unit will automatically switch off. If users want to turn off the LCD immediately, just pull out the plug directly. When the plug is pulled out, the residual heat warning function cannot be run.

7. Stirring (LCD digital model)

The function "stirring" is switched on or off via rotating stirring knob. The speed is set on the knob (100 to 1500 rpm in steps of 10 rpm). When both of function heating and stirring are switched on and those above operations are done, the LCD will shift to the speed value and come back to the temperature value in about 5 seconds.

8. Remote Control (LCD digital model)

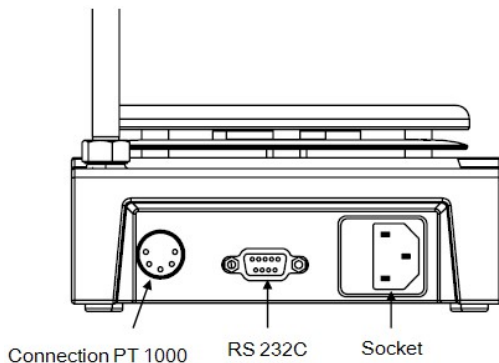

Figure 7

The unit can be controlled from an external PC (using the dedicated software) via the RS232C serial interface fitted to the unit. Data communication from laboratory instrument to computer is only possible on demand of the computer.

- The functions of the interface lines between laboratory instrument and automation system are selected from the specified signals of the EIA-standard RS232C, corresponding with DIN66020 Part 1. The allotment of the bushing can be taken from Figure 7
- Transmission method: Asynchronous signal

transmission in start-stop-operation.

- Mode of transmission: Fully Duplex. 1 start bit; 7 character bits; 1 parity bit [straight (even)]; 1 stop bit.
- Transmission speed: 9600 bit/s
- Start remote control knob LCD display “ Remote ”.



Note:

Forbid to insert or remove the RS232C communication line when switch on!

9. Faults

- Instruments can't be power ON
 - Check whether the power line is unplugged
 - Check whether the fuse is broken or loose
- Fault in power on self test
 - Switch OFF the unit, then switch ON and reset the instruments to factory default setting.
- Stir speed cannot reach set point
 - Excessive medium viscosity may cause abnormal speed reduction of the motor
- Unit cannot be powered off when switched off.
 - Check if the residual heat warning function is still ON and hotplate temperature is above 50°C (the LCD still work and “Hot” flash).

If these faults are not resolved, please contact manufacturer/supplier.

10. Maintenance and Cleaning

- Proper maintenance can keep instruments working properly and lengthen its lifetime.
- Do not spray cleanser into the instrument when cleaning.
- Unplug the power line when cleaning.
- Only use recommended cleansers:

Dyes	Isopropyl alcohol
Construction materials	Water containing tenside / Isopropyl alcohol
Cosmetics	Water containing tenside / Isopropyl alcohol
Foodstuffs	Water containing tenside
Fuels	Water containing tenside

- Before using other method for cleaning or decontamination, the user must ascertain with the manufacturer that this method will not harm the instrument. Wear the proper protective gloves during cleaning of the instrument.



Note:

- Electronic device can not clean with cleanser.
- If you require maintenance service, must be cleaned the instrument in advance to avoid pollution of hazardous substances, and to send back into original packing.
- If the instrument will not use for a long time, please switch off and place in a dry, clean, room temperature and stable location.

11. Associated Standards and Regulations

Construction in accordance with the following safety standards:

EN 61010-1

UL 3101-1

CAN/CSA C22.2(1010-1)

EN 61010-2-10

Construction in accordance with the following EMC standards:

EN 61326-1

Associated EU guidelines:

EMC-guidelines: 89/336/EWG

Instrument guidelines: 73/023/EWG

Changes or modifications not expressly approved by the party responsible for compliance could void the user's authority to operate the equipment.

NOTE: This equipment has been tested and found to comply with the limits for a Class A digital device, pursuant to Part 15 of the FCC Rules. These limits are designed to provide reasonable protection against harmful

interference when the equipment is operated in a commercial environment. This equipment generates, uses, and can radiate radio frequency energy and, if not installed and used in accordance with the instruction manual, may cause harmful interference to radio communications. Operation of this equipment in a residential area is likely to cause harmful interference in which case the user will be required to correct the interference at his own expense.

12. Specifications

Items	Specifications	
	Digital model	Classic model
Voltage [VAC]	100-120/200-240	100-120/200-240
Frequency [Hz]	50/60	50/60
Power [W]	*550 50	*530 30
Stirring point position quantity	1	1
Max. stirring quantity (H ₂ O) [l]	20	20
Max. magnetic bar [L× ϕ , mm]	80×10	80×10
Motor type	DC brushless motor	
Max. power input of motor [W]	18	18
Max. power output of motor [W]	10	10
Speed range [rpm]	100-1500, increment: 10	0-1500
Rotary speed display	LCD	Scale

Items	Specifications	
Plate material	Stainless steel with ceramic coated	
Dimensions of workplate (mm)	ϕ 135	ϕ 135
*Heating power [W]	500	500
*Temperature range [°C]	RT-340, increment: 1	RT-340
*Temperature display [°C]	LCD	Scale
*Temperature display accuracy [°C]	± 0.1	-
*The safe temperature of hotplate [°C]	360	100-350
*Temperature sensor in medium	PT1000	-
*Control accuracy of heating temp with temp sensor [°C]	± 0.2	-

Items	Specifications	
*Residual heat warning	50°C	-
Dimensions (mm)	280×160×85	
Weight [kg]	2.8	2.8
Permitted ambient temperature [°C]	5-40	
Permitted relative humidity	80%	
Protection class acc. to DIN 60529	IP42	
RS232 interface	Yes	No

*Hotplate model

Table 4

(加热型) 磁力搅拌器

使用说明书

LCD 数控加热型磁力搅拌器

标准加热型磁力搅拌器

LCD 数显型磁力搅拌器

标准型磁力搅拌器



请仔细阅读说明书并在说明书的操作指导下安全使用本仪器。

外形和性能指标如有变动，概不另行通知。

目录

前言	1
如何获取帮助	1
质量保证	1
1. 安全事项	2
2. 使用范围	3
3. 检查	3
3.1 开箱检查	3
3.2 装箱清单	3
4. 控制与显示	4
4.1 控制	4
4.2 显示 (LCD 数控型)	6
5. 操作	6
6. 加热功能(LCD 数控加热型)	7
6.1 外置温度传感器	7
6.2 余热警告 (HOT)	8
7. 搅拌功能	8
8. 远程控制 (LCD 数控型)	8
9. 故障诊断	9
10. 维护和清理	9
11. 相关标准	10
12. 技术参数	10

前言

欢迎使用《(加热型) 磁力搅拌器使用说明书》。用户在使用本仪器前应仔细阅读本说明书，按说明书指导进行操作，并了解各种注意事项。

如何获取帮助

如果您在安装和使用的过程中遇到任何问题或需要帮助，请及时与制造商/供货商的售后服务部门取得联系，制造商的联系方法如下：

请您准备以下资料：

- 产品序列号（仪器铭牌上）
- 质保卡
- 问题现象的描述
- 您为了解决问题所采取的方法及操作步骤
- 您的电话、传真和 Email 地址等联络方式

质量保证

根据制造商的质量保证条款，在本说明书规定的正常使

用条件和操作方法下使用该仪器时，该仪器的保修期为 24 个月（自购买之日起）。由于错误安装与操作、私自拆卸与维修以及其他违反说明书中规定的操作条款造成的仪器性能下降和损坏，不能按照本质量保证进行维修。如出现质保条款中的相关问题，请联系制造商/供货商。

1. 安全事项

	<p>警告!</p> <ul style="list-style-type: none"> 操作仪器前请认真阅读本说明书并遵守安全操作规范。 经过专业培训的人员才能操作本仪器。
	<p>小心烫伤!</p> <ul style="list-style-type: none"> 当触摸仪器底座和加热盘时请注意, 本仪器加热盘的最高温度为 340 °C。 仪器关闭后加热盘会有余温, 请避免烫伤。
	<p>安全接地保护!</p> <ul style="list-style-type: none"> 为保证安全, 使用本仪器前请确认电源插座已良好接地。

- 工作时, 请穿戴合适的防护设备, 否则可能由于以下事项引发危险:
 - 搅拌液体溅出和蒸汽
 - 释放出的有毒、易燃气体
- 请把仪器置于宽敞通风的区域内使用, 并确保工作台面平稳、干净、防滑、干燥及防火。请勿在室外、危险物质环境及水中运行本仪器。
- 缓慢调节转速, 出现下列情况时, 请调低转速:
 - 仪器运行不稳, 容器在加热盘上移动
- 设置温度必须低于样品燃点 50°C。

- 注意避免进行以下危险操作:
 - 搅拌沸点低的易燃样品
 - 搅拌样品过量灌装
 - 使用不安全的容器
- 搅拌致病样品时, 必须使用密闭的容器。
- 使用搅拌子的外壳为聚四氟乙烯 (PTFE) 时, 请注意:
 - 常温下, 单质氟, 三氟化物和碱金属会腐蚀 PTFE, 卤烷烃会使其膨胀
 - 碱或碱土金属熔融态或其溶液以及元素周期表的第二族和第三族的粉末在温度达到 300~400°C 之间时会与 PTFE 发生化学反应。
- 每次开启仪器之前请确认仪器及其配件未损坏。请使用“配件”章节中列出的标准配件, 并依照说明书使用配件, 以确保安全。配件务必牢固的连接在仪器上, 避免脱离。在装卸配件之前请先断电。
- 外置温度传感器的顶端至少距离容器底部 5-10mm, 距容器壁 5-10mm。
- 仪器只能通过拔掉电源插头才能完全断电。
- 请确保使用电源电压跟铭牌要求的一致。
- 确保电源线远离加热盘, 仪器在使用时禁止遮盖。
- 只有经过专业训练的人员才能打开本仪器。
- 请勿在强磁场区域使用本仪器。

2. 使用范围

本仪器是为学校、实验室和工厂等应用环境设计的，用于对液体进行加热及搅拌，供以下环境使用：

- 海拔不超过 2000 米
- 温度在 0℃到 40℃
- 安装类型：产品是为了连接室内插座而设计的，电压波动不超过正常值的±10%
- 仪器间、仪器与墙壁的最小距离为 100mm。



图 1

本仪器不适合在住宅区以及第 1 章中规定的一些限制条件下应用。

3. 检查

3.1 开箱检查

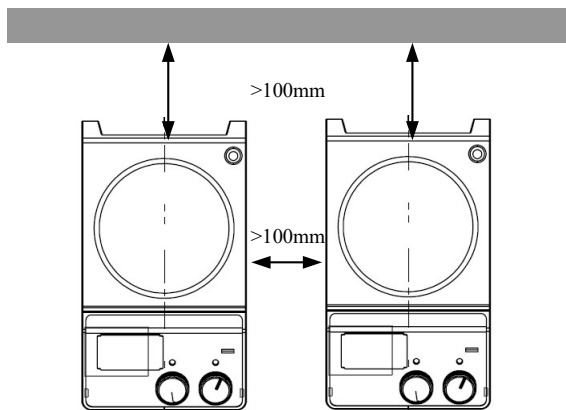
用户如发现任何包装损伤，请在收据上注明。在打开包装后如果发现任何内部损伤，请联系制造商/供货商。



注意：

如发现仪器上有任何明显的损伤，请不要将其连接到电源。

3.2 装箱清单

名称	数量
主机	1 台
电缆	1 根
搅拌子	1 个
使用说明书	1 本

表 1

1. 控制与显示

4.1 控制



图 2 LCD 数控型



图 3 标准型

图 4

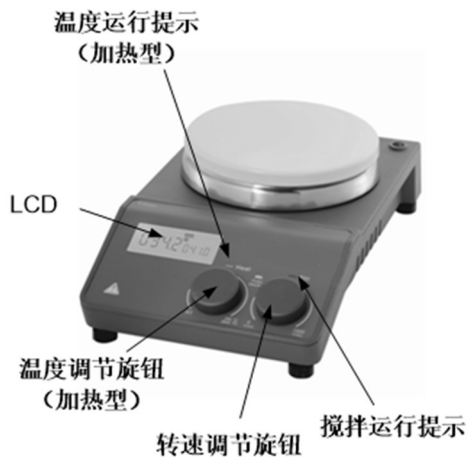
	名称	说明
LCD 数控型	温度调节旋钮 Heat (加热型)	设定室温-340℃范围内的控制温度，按下旋钮开启、关闭加热功能
	转速调节旋钮 Stir	设定 100-1500rpm 范围内的转速，按下旋钮开启、关闭搅拌功能
	LCD 显示	液晶显示屏显示仪器当前工作状态及各项设置
	温度运行指示(加热型)	开启加热功能，“Heat” 灯亮
	搅拌运行指示	开启搅拌功能，“Stir” 灯亮
	电源开关	打开、关闭仪器主电源

标准型	温度调节按钮 Heat (加热型)	设定室温-340℃范围的控制温度。旋动旋钮开启、关闭加热功能。
	电机调节按钮 Stir	设定 0-1500rpm 范围的转速，旋动旋钮开启、关闭搅拌功能。
	温度运行提示 (加热型)	加热过程中“Heat”灯点亮。
	搅拌运行提示	打开电源后，“Stir”灯点亮。
	电源开关	打开、关闭仪器主电源。

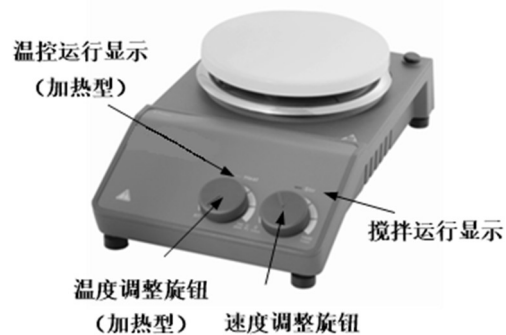
表 2

4.2 显示（LCD 数控型）



图 5

显示	说明
Temp & °C	加热功能开启时显示
Stir	搅拌功能开启时显示
Hot	无论加热功能是否开启，如果加热盘的温度高于 50°C，显示高温警示
Probe	插入外置探头时显示
Remote	进行远程控制时显示
Err	仪器发生故障时显示
设定值/实际值	加热功能、搅拌功能开启时显示数值

表 3

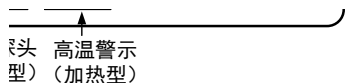

注意：

加热和搅拌功能同时开启时，优先显示温度值。如果此时操作电机调节按钮 **Stir**，切换到转速值显示，5 秒钟后恢复显示温度值。

2. 操作

- 检查铭牌上指定的工作电压与电网电压是否匹配
- 电源插座要求接地良好
- 打开电源，进行开机自检
- 选用合适的搅拌子放入容器中，注入待搅拌样品
- 把容器放到仪器盘面上
- 设置搅拌速度并启动搅拌
- 观察搅拌子工作情况
- 设置加热温度并启动加热（加热型）
- 观察液晶屏上显示的实际温度情况（数显加热型）
- 关闭加热功能（加热型）和搅拌功能

如果上述操作运行正常，说明仪器可以开始正式使用。如果运行不正常，仪器可能已经在运输过程中损坏，请与制造商/供货商售后服务中心取得联系。



注意：

仪器运行过程中请不要将容器移走，一旦容器

脱离仪器的工作盘表面，再次放置容器前要停止搅拌功能，容器放置好后再次启动搅拌。

3. 加热功能(LCD 数控加热型)

系统设置有两个独立的安全回路，用来控制加热盘的温度恒定。安全检测回路可以监测加热盘的温度；加热盘内置的两支温度传感器 PT1000 实现温度监控功能；外接的 PT1000 温度传感器可以监控样品的温度。

- 连接好外置温度传感器
- 用温度调节按钮来设置需要控制的温度；
- 加热功能开启时，Heat 灯亮，同时液晶屏的左侧显示实际温度。
- 液晶屏右侧显示设置温度值，同时显示 **Temp** 和 **°C** 字符；
- 按下温度调节按钮开启/关闭加热功能。

仪器开启时设置区的温度为上次关机时的设置温度，在常用情况下，设置的加热温度显示值与以下实际温度可能有差异：

- 加热盘中心与外沿
- 容器与容器中的样品

这些差异存在是由于热传导特性造成的，为了确保容器内温度的精确性，请使用外置温度传感器 PT1000。

6.1 外置温度传感器



图 6

本机使用的外置温度传感器PT1000，为制造商的标准选配件。接入外置温度传感器后，“Probe”字符一直显示，表示外置温度传感器开始工作。液晶屏显示外置温度传感器的设置温度和实际温度，安全检测回路限制加热盘温度。相对于加热盘温控，外置温度传感器可以更精确地控制样品的温度。外置温度传感器必须放置在被加热样品中，如果检测到异常情况，加热模块会自动关闭，此时请进行如下操作：

- 关闭电源
- 确保外部温度控制器浸入被加热样品中
- 打开电源，设置目标温度并开启加热功能
- 仪器如果没有恢复正常工作，请联系制造商/供货商。

6.2 余热警告 (HOT)

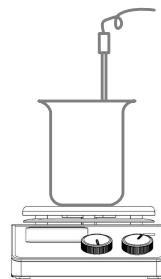
为防止加热盘烫伤，加热型具有余热警告功能 (Hot)：加热功能关闭后，如果加热盘的温度仍然维持在 50°C 以上，液晶屏上“Hot”字符出现，警告加热盘温度过高，有烫伤危险。关闭仪器的主开关后，液晶屏显示内容持续闪烁，实际值区交替显示当前加热盘温度和“Hot”字符，这时用户仍然可以设置转速等参数，当加热盘的温度降到 50°C 以下后，仪器自动断电。

如果用户需要立即关闭液晶屏，可以直接拔掉电源插头。主电源故障或者电源插头拔出的情况下，不能运行余热警告功能。

4. 搅拌功能 (数显型)

仪器采用闭环回路控制电机，电机驱动永磁铁旋转。通过转速调节旋钮可以设置电机转速，转速调节范围是 100-1500rpm，步进量为 10rpm，按下转速调节按钮可以打开/关闭搅拌功能。当同时开启加热和搅拌功能时，如进行上述操作，液晶屏切换到显示转速值，5秒钟后恢复显示温度值。

仪器开启时设置区的转速为上次关机时的设置转速。

5. 远程控制 (LCD 数控型)



图 7

可以通过 RS232C 连接外部 PC 对仪器进行控制 (使用专用软件)，仪器到计算机的数据通信只能由计算机主动发出请求。

- 实验室仪器与自动控制系统之间的连接线采用指定的 EIA 标准 RS 232C 通信线，对应的 DIN 66020 Part 1 接口，参考图 7 所示连接线和接口的分配。
- 通信方式：双向异步串行通讯。
- 1 起始位、8 位字符、1 停止位。
- 传输速率：9600 bit/s

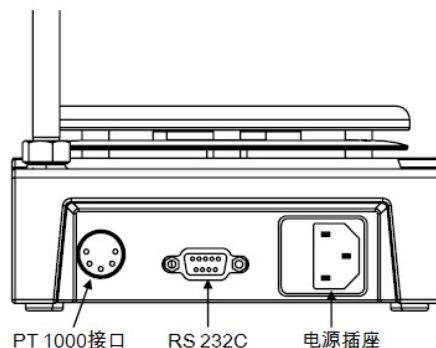

注意：

禁止在开机状态下拔插串口线

6. 故障诊断

- 打开电源仪器不启动
 - 请检查电源线是否连接牢靠
 - 请检查电源保险管是否损坏或松动
- 仪器开机自检不正常
 - 请关闭仪器，重新启动。
- 转速无法达到设定值
 - 该功能在介质液体粘度过高时可能造成不正常减速
- 关闭仪器电源时仪器不断电
 - 加热盘温度高于 50℃，余热警告功能开启

如果故障没有排除，请联系制造商/供货商。

7. 维护和清理

正确地使用和维护仪器，使其处于良好的工作状态，可以延长仪器的使用寿命。常规工作中请保持仪器干燥与洁净，迅速除去溢出液体，使用非研磨清洁剂清理外表面，在所有表面干燥之前请不要连接电源。如果液体或者潮湿固体进入仪器内部，请迅速断开电源不再使用，联系制造商/供货商获得更多建议。

- 保持仪器整洁，切勿使清洗溶液流入机内。
- 维护和清理之前必须断电，请使用我们推荐的方法

清理仪器。祛除方法：

染料	异丙醇
建筑材料	含活性剂的水溶液/异丙醇
化妆品	含活性剂的水溶液/异丙醇
食物	含活性剂的水溶液
燃油	含活性剂的水溶液

- 上表没有列出的材料，可以咨询制造商。在采用其他清理方法之前，用户必须与制造商/供货商确认该方法不会损坏仪器。清理仪器时，请戴上合适的防护手套。



注意：

- 电子设备不能用清洁剂清理。
- 送修仪器必须清理，同时避免危险物质的污染，并把仪器放回原始包装箱发送。
- 当产品长期不用时，请将仪器断电存放，并置于干燥、洁净、常温、平稳处。

8. 相关标准

仪器结构符合以下安全标准

EN 61010-1

UL 3101-1

CAN/CSA C22.2(1010-1)

EN 61010-2-10

仪器结构符合以下电磁兼容标准

EN 61326-1

符合以下欧盟标准

EMC 标准： 89/336/EWG

机械设计标准： 73/023/EWG

9. 技术参数

项目	参数	
	数控型	标准型
电压 [VAC]	200-240 / 100-120	
频率 [Hz]	50 / 60	50 / 60
功率 [W]	*550	*530
	50	30
搅拌点位数量	1	
最大搅拌量(H ₂ O) [L]	20	
搅拌子最大长度 [L×Ø,mm]	80×10	
电机类型	直流无刷电机	
电机输入功率 [W]	18	
电机输出功率 [W]	10	10
速度范围 [rpm]	100-1500, 步长: 10	0-1500
转速指示	LCD	刻度
加热盘材质	不锈钢陶瓷涂层	
加热盘尺寸 [mm]	Ø 135	
*热输出功率 [W]	500	500
*加热温度范围 [°C]	室温- 340, 步长: 1	室温 - 340
*温度显示	LCD	刻度

项目	参数	
*温度显示分辨率 [°C]	±0.1	-
*安全温度 [°C]	360	350
*外置温度传感器	PT1000	-
*外置温度传感器控温精度 [°C]	±0.2	-
*余热警告功能	50°C报警线	-
外形尺寸 [WxDxH ,mm]	280×160×85	
重量 [kg]	2.8	
允许环境温度 [°C]	5 – 40	
允许相对湿度	80%	
DIN EN60529 保护方式	IP42	
RS232 接口	有	无

*加热型

表 4